

MANUAL for

UNIVERSAL SPRING COMPRESSOR 91XL-21

(SC91-010XL-21)

Read this manual before you start to work with the SC91XL-21.

SC91XL-21 designed and made by:

LEURS PRECISION

Nijverheidsweg 11
2821 AT Stolwijk
Holland

Tel.: +31(0)182-342342
info@leursprecision.nl
www.leursprecision.

INTRODUCTION

The Universal Spring Compressor 91XL-21 (SC91XL) is intended as a tool for the changing of main springs of air rifles.

By using the SC91XL changing of these springs can be done safer, with much less physical force and without damaging the rifle.

The SC91XL is suitable for almost all types of air rifles.

SAFETY

1. **Read this manual carefully, before using your SC91XL.**
2. Check in a safe way and in safe direction if the air rifle, of which you want to change the spring, is not loaded and is not cocked. (See the manual of the air rifle)
3. Wear safety goggles when using the SC91XL.
4. Use no "violence" when using the SC91XL. Due to the many different air rifle constructions, you sometimes have to try how the air rifle can fit the SC91XL. If so, do this safe.

PREPARING WORK

1. Put the SC91XL with the middle of the frame in a vice, or with a clamp on a workbench. Take care not to damage the SC91XL, do not "compress" the SC91XL.
2. Read the air rifle manual for how to prepare the air rifle for changing the spring of the air rifle.
3. Air rifles with the end plug screwed in the cylinder (as example Weihrauch HW77 or HW85), screw out the end plug a few turns.

USING the SC91XL

1. Place the air rifle as follows in the SC91XL (see figure 1):
 - move clamp blocks ("V-blocks") so that the SC91XL fits the rifle.
 - if necessary turn the air rifle around until it fits the SC91XL.
 - **place stop disc (1) over the barrel, in the recess of the frame.** (otherwise the rifle will shift out of the SC91XL)

There are 3 different stop discs supplied, one with a slot of 16.5mm, one with a slot of 21mm, and one without a slot

The stop disc without a slot can be, if necessary, adapted to an air rifle.

Pay especially attention if the adapted stop disc is still strong enough and can be used safely as intended.

2. Clamp the air rifle in the SC91XL by putting the two clamp covers (2) over the air rifle cylinder. Tighten the clamp covers with the four knurled nuts (3).
3. Air rifles where a safety knob protrudes out of the end of the end plug (for example Webley Eclipse) should, for preventing damage to this knob, be put a wooden or plastic piece between the end plug and the push block (4).

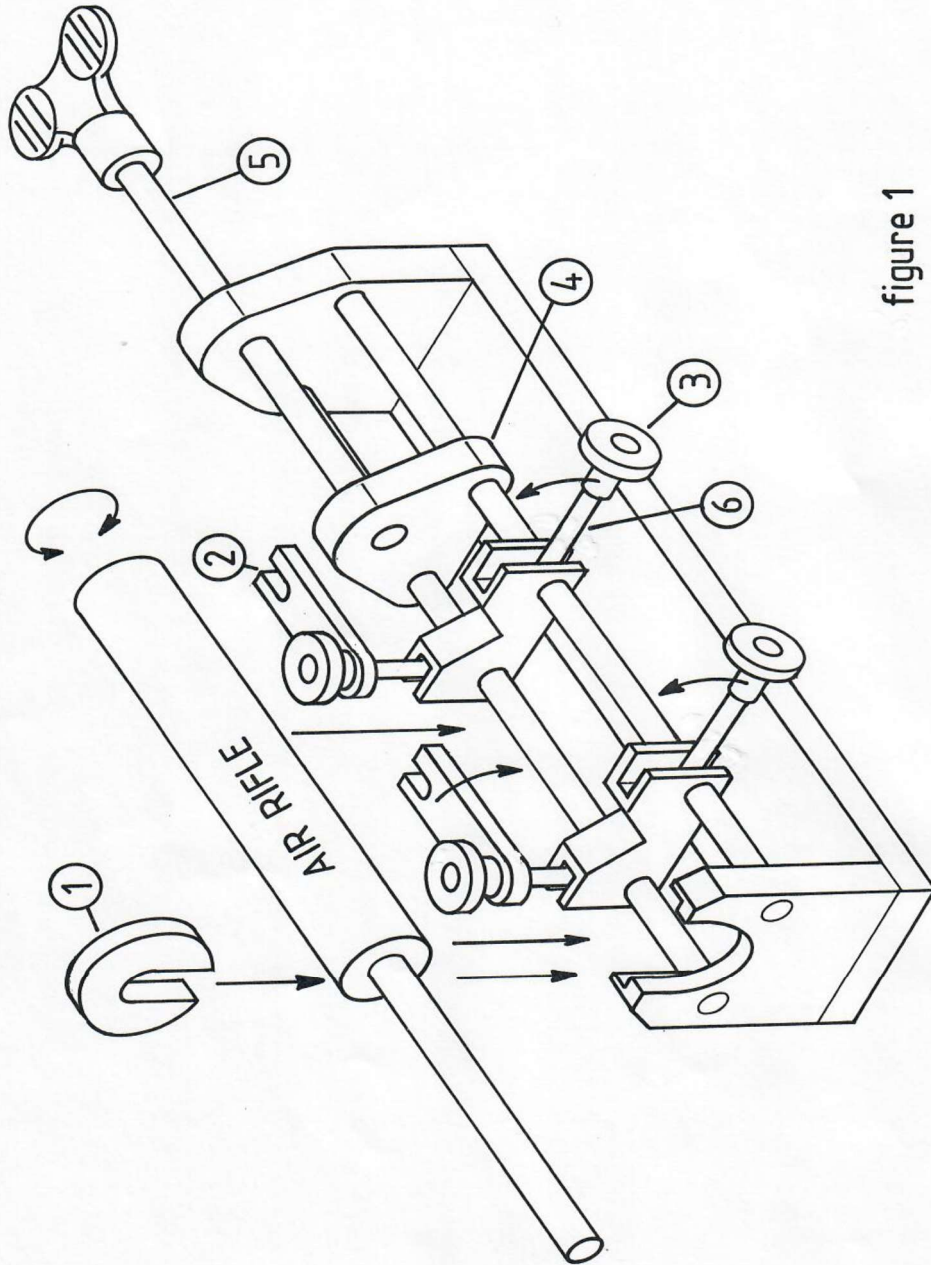

figure 1

4. If the air rifle is clamped properly in the SC91XL, put the end plug with the threaded spindle (5) under such a (small) tension, that:

ATTENTION: Always guide mainspring and end plug with the threaded spindle (5) until there is no more tension of the mainspring.

or, under guidance of the threaded spindle the end plug can be screwed out (for example Weihrauch HW80).

or, the cross pin can be pushed out, then guide the end plug and mainspring (for example Webley-Eclipse).

or, screw out the screw at the bottom of the cylinder (with which the end plug is hold in the cylinder), after that guide the end plug and the mainspring. (for example BSF-S60).

5. If the mainspring is not forcing anymore against the screw spindle, then take the rifle out of the SC91XL and remove the main spring.
6. Place the (new) mainspring and end plug in the cylinder.
(Tip for reassembling Weihrauch-air rifles with a screwed in end plug: make a mark on 2 pieces of tape to note the proper position of the start of the screw thread of the cylinder and of the end plug, this makes reassembling easier)
7. Clamp the air rifle again in the SC91XL, **don't forget the stop disc (1)**. Then execute point 4. in reverse way.
8. Take the air rifle out of the SC91XL, and assembly the rifle according the air rifle manual. Check if the rifle is functioning safe and properly.

MAINTENANCE of the SC91XL

See figure 2. Keep the eye bolts (6), knurled knobs (3) and threaded spindle (5) free of dust and grease these steel parts lightly to prevent corrosion and friction/galling.

SC91XL should be stored dry.

Before using the SC91XL check it on defects or damage which could let to unsafe situations.

GUARANTEE of the SC91XL

The SC91XL will be guaranteed against faulty workmanship and defective materials for a period of two years from the original date of purchase.

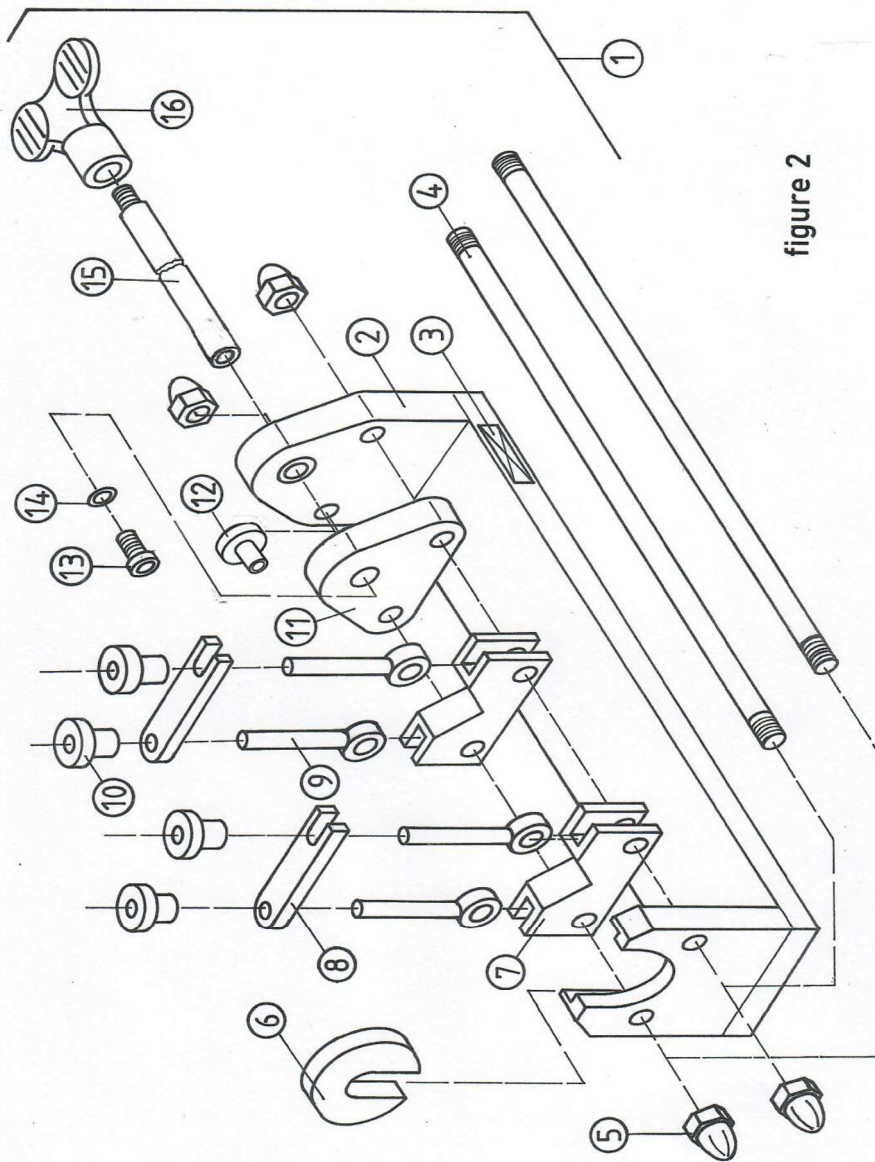

figure 2

REPAIRING of the SC91XL-21

Underlined parts are assembled with a locking fluid of medium strength (for example Loctite 243). Tighten the domed cap nuts (SC91-105) by hand, not with a spanner. The Allen screw (SC91-140-21) and the wing nut (SC91-155) are screwed on the threaded spindle (SC91-150XL-21).

When ordering parts always refer to: part number/description/quantity needed.

No.	Part number	Description	Quantity
1	SC91-010XL-21	Universal Spring Compressor 91XL-21, assembly	-
2	SC91-20XL	frame	1
3	SC91-040XL-21	sticker	1
4	SC91-100XL	guide rod	2
5	<u>SC91-105</u>	<u>domed cap nut (DIN 1587-M12-CHROME)</u>	<u>4</u>
6A	SC91-165	stop disc, with slot 16.5mm	1
6B	SC91-210	stop disc, with slot 21mm	1
6C	SC91-114	stop disc, without slot	1
7	SC91-115	clamp block	2
8	SC91-120	clamp cover	2
9	SC91-125	eye screw	4
10	SC91-130	knurled nut (DIN 466-M8-BLACK)	4
11	SC91-135	push block	1
12	SC91-147-21	thrust bush	1
13	SC91-140-21	Allen screw (DIN 912-M5x25-8.8)	1
14	SC91-145	washer (DIN125B-5,3-140HV)	1
15	SC91-150XL-21	threaded spindle	1
16	<u>SC91-155</u>	<u>wing nut</u>	<u>1</u>
-	SC91-200E-XL-21	manual, English	1
-	SC91-200NL-XL-21	gebruiksaanwijzing (manual), Nederlands (Dutch)	1

SPECIFICATION

weight : 8.8 lbs (4.2 kg)
 dimensions : 32.4" x 3.4" x 5.5" (822 x 86 x 140 mm)

English manual 4st May 2023
Part number manual: SC91-200E-XL-21